

# ONDERDELENLIJST

Pos. : 20900  
Equipment TAG No. : 100-X410; 100-X420; 100-X430  
Instrument TAG No. :

**Maschine : SCHUIFAFSLUITER**

Type : SFP 600X270 S

Machinenummer :

Artikelnummer : K3564-0084

Opdrachtnummer : 64.350 / 10

Voor onderdelenbestellingen van de aparte componenten, zijn de delen via de positienummers van de onderdelentekeningen te herkennen.

## Voorbeeld

Pos. nr.	* Onderdeel kenmerk	Aantal	Eenheid	Artikelnummer	Beschrijving
0130	E, L	1,000	ST.	K 6251-1016	Flenslagerhuis

\* V, L = slijtdeel voorraadartikel; E, L = reserve onderdeel voorraadartikel;  
E = reserve onderdeel met levertijd; V = slijtdeel met levertijd

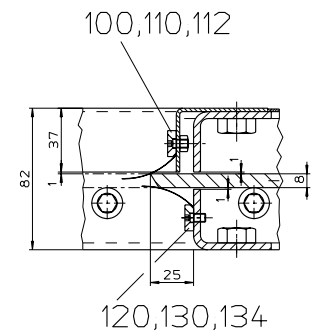
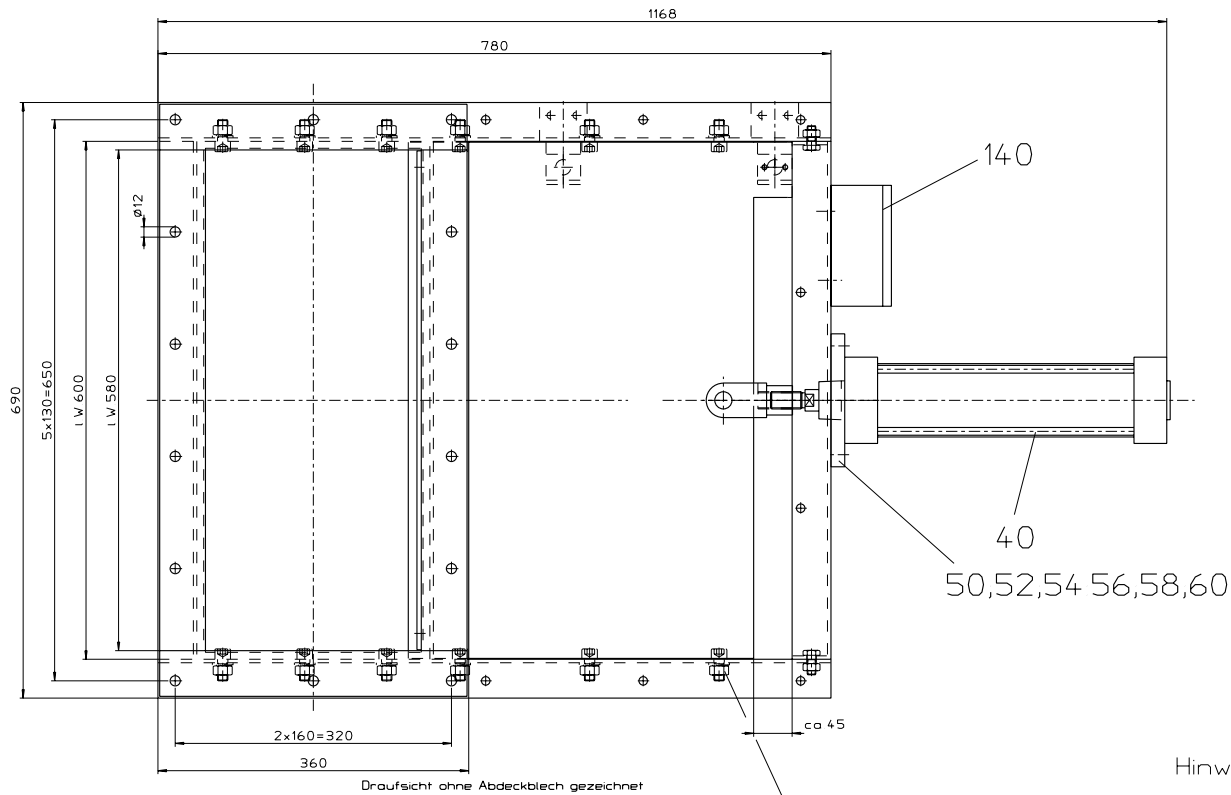
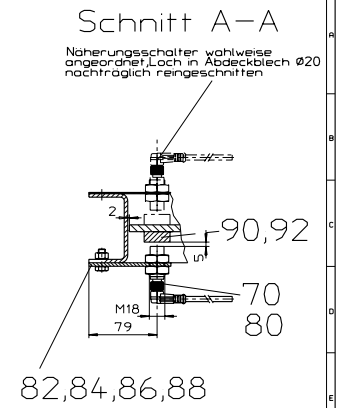
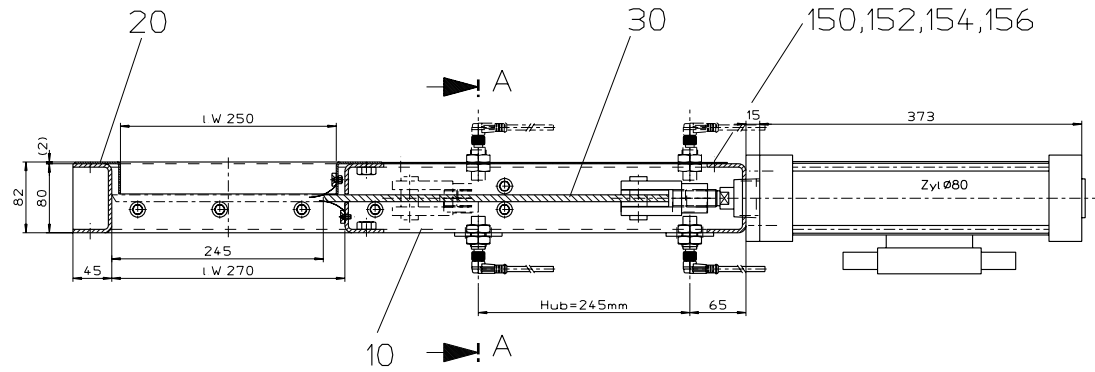

Hinweis Schieber mit Maßblatt 3564-0083-A  
 ist Ersatz für Maßblatt 3564-0050-B

№	Größe	Best.Nr.	Rev.	Benennung
1	3564-0083-A			Schieber SFP 600x270
2	3564-0083-A			Schieber SFP 600x270
3	3564-0083-A			Schieber SFP 600x270
4	3564-0083-A			Schieber SFP 600x270
5	3564-0083-A			Schieber SFP 600x270
6	3564-0083-A			Schieber SFP 600x270
7	3564-0083-A			Schieber SFP 600x270
8	3564-0083-A			Schieber SFP 600x270
9	3564-0083-A			Schieber SFP 600x270
10	3564-0083-A			Schieber SFP 600x270
11	3564-0083-A			Schieber SFP 600x270
12	3564-0083-A			Schieber SFP 600x270
13	3564-0083-A			Schieber SFP 600x270
14	3564-0083-A			Schieber SFP 600x270
15	3564-0083-A			Schieber SFP 600x270
16	3564-0083-A			Schieber SFP 600x270
17	3564-0083-A			Schieber SFP 600x270
18	3564-0083-A			Schieber SFP 600x270
19	3564-0083-A			Schieber SFP 600x270
20	3564-0083-A			Schieber SFP 600x270
21	3564-0083-A			Schieber SFP 600x270
22	3564-0083-A			Schieber SFP 600x270
23	3564-0083-A			Schieber SFP 600x270

Maßstab 0 50 100 150 200

Druckvermerk: 81833-001 © 2008/2011 by KÄHLER & CO. AG, Nürnberg

A K T B D	Telephone: 040/727 71-0 Fax: 040/727 71-100 Date: 06.09.2010	S P A R E P A R T L I S T  Sheet: 1  3564-0083-A
--------------	---	--

ITEM	S	L	QUANTITY	UQ	PART NO.	DESIGNATION
------	---	---	----------	----	----------	-------------

<b>K3564-0084 SLIDE GATE SFP 600X270 S SCHIEBER SFP 600x270;24V-;ATEX_ZONE 2</b>						
--	--	--	--	--	--	--

0040	E		1,000	ST	K6427-0296	SLAVE UNIT, PNEUMATIC ARBEITSEINHEIT PNEUMATISCH
0070	E	L	2,000	ST	K9044-0209	<b>INDUCTIVE PROXIMITY SWITCH NAEHERUNGSSCHALTER, INDUKTIV</b>
0080	E	L	2,000	ST	K9044-0133	CABLE BOX KABELDOSE
0110	E	L	1,000	ST	K3564-4273	<b>Precision gauge belt PRÄZISIONSLEHRENBAND</b>
0112	E	L	7,000	ST	K6026-0101	COUNTERSUNK SCREW SENKSCHRAUBE M. INNENSECHSKANT
0130	E	L	1,000	ST	K3564-4274	<b>Precision gauge belt PRÄZISIONSLEHRENBAND</b>
0134	E	L	8,000	ST	K6026-0101	COUNTERSUNK SCREW SENKSCHRAUBE M. INNENSECHSKANT